

## **Fundamentals of a Theory of Aether – Part 2**

(Released : August 1<sup>st</sup>, 2021 ; Last updated : August 27<sup>th</sup>, 2021)

Ionel DINU, B.Sc. Physics, M.Sc. Physics, Teacher of Physics QTS

Email : [dynuionel@yahoo.com](mailto:dynuionel@yahoo.com)

LinkedIn : [www.linkedin.com/in/ionel-dinu-74490634](http://www.linkedin.com/in/ionel-dinu-74490634)

### *Abstract*

In this work computational fluid dynamics (CFD) is for the first time applied to the field of electrostatics. It is possible to treat electrostatics mechanically because the interacting particles, which present science calls “charged with electricity”, are in this theory considered to be *charged with energy*, vibrating and transmitting their vibrations to one another through the liquid aether. The aim of this work is to show that the concept of “electric charge” in use today, employing action at a distance and explaining nothing as to how the action of charged particles on one another takes place, can be replaced with the concept of *energy charge* which, besides being simpler, has the advantage of offering a mechanical explanation of the electrostatic action. The attractions and repulsions produced by *energy charged* particles vibrating in a liquid are consistent with those observed in electrostatic phenomena, which makes the concept of “electric charge” an unnecessary and artificial invention.

*Keywords:* aether, energy charge, electric charge, electrostatics, action at a distance, CFD

## Introduction

In “The Origin of Gravitation” (2007) [1] the action of the ubiquitous force of gravity was explained as a buoyancy force in the aether, the aether pressure gradient necessary for its action being produced by the powerful radiation of a star or by the weaker radiation of a planet or of other colder type of celestial body. The theory was successful in accounting for the action at a distance of gravity, for its dependence on the inverse square of the distance between objects and on the quantity of matter in each object, tracing its cause to the thermal energy of the body producing the gravitational force and thus offering a reasonable explanation why gravity is only attractive and not repulsive as well. Below is figure 3 from that work [1].

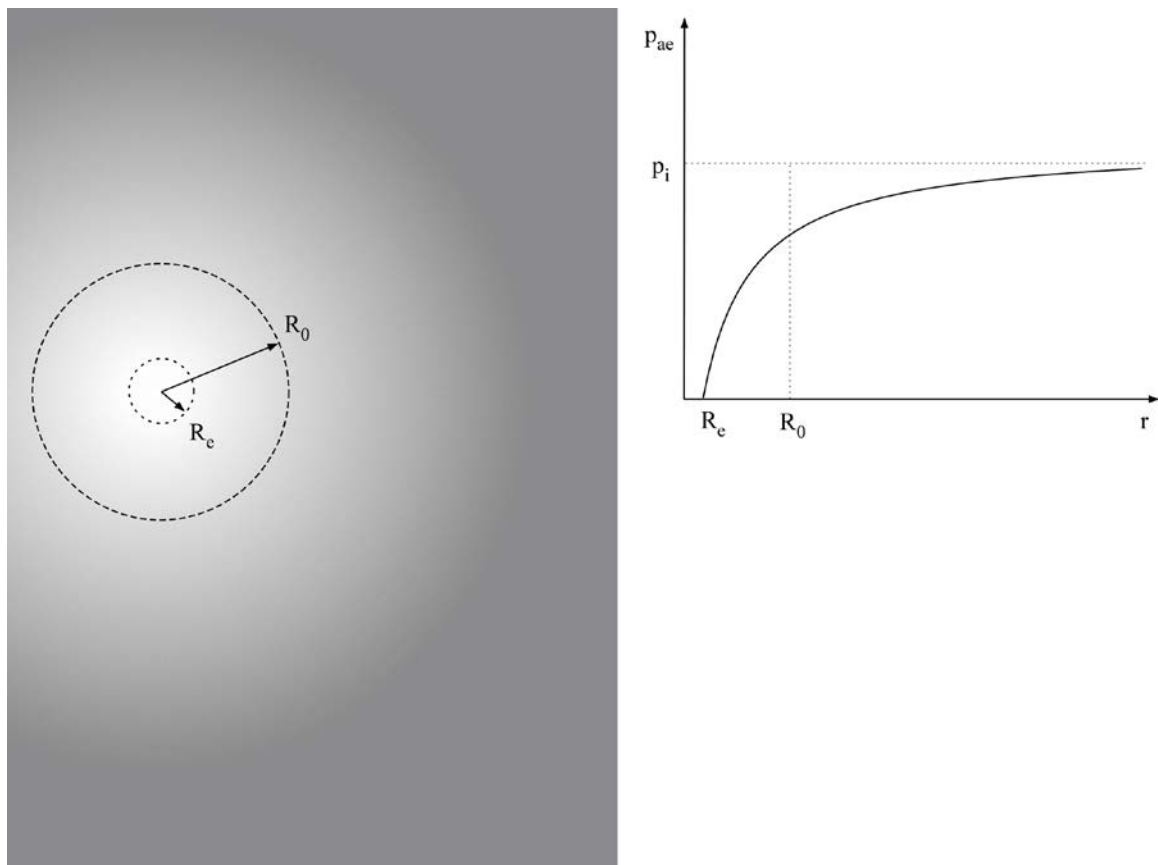
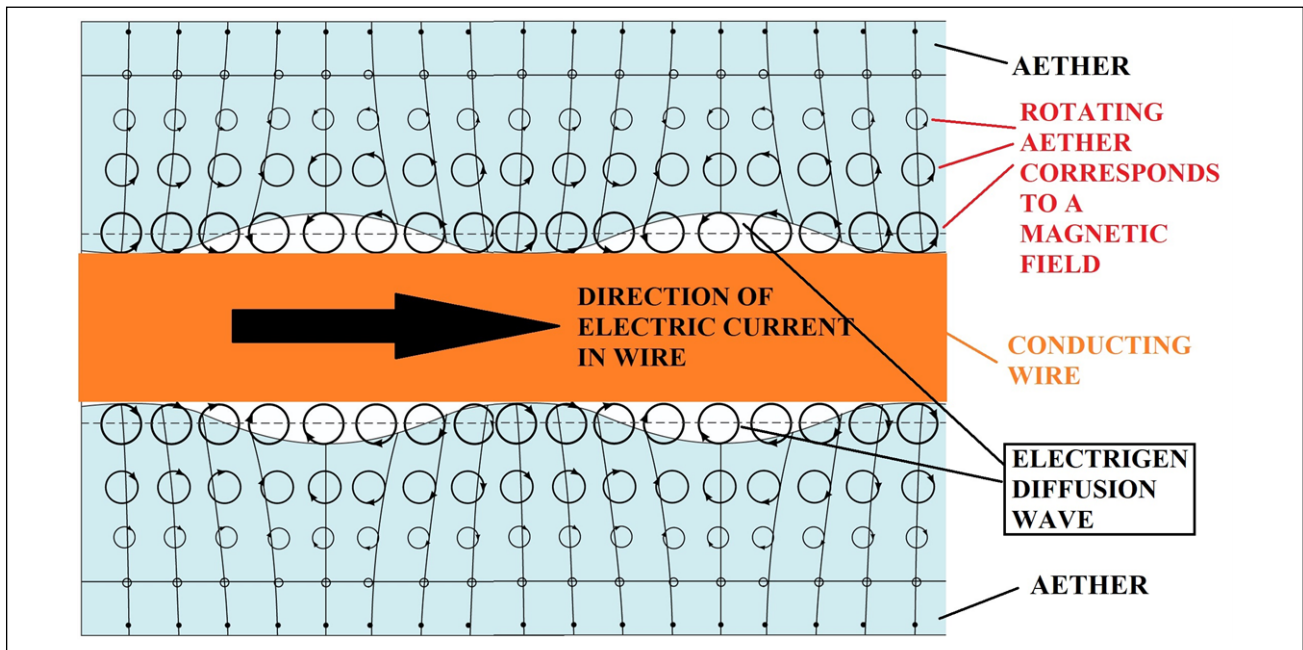

Fig. 3. The radial distribution of aetherial pressure around a hot body of radius  $R_0$  situated in Torricellian vacuum or interstellar space. The radiation originating from the body exerts pressure on the surrounding matter including the aether. The aether is pushed away from the center of the hot body and further beyond its geometric boundary creating an aether pressure gradient indicated in figure by gradient color. The aether pressure is low in the vicinity of the body and approaches the interstellar value  $P_i$  at large distances from its center where the radiation pressure becomes negligible, according to eqn. 14. The hot body practically impinges on the aether radially in all directions and creates a region of decreased aether pressure in its neighborhood. Any object situated there is pushed towards the center of the hot body by the aetherial Archimedic force that is born within this region. Such a radiating body in the interstellar space generates a gravitational field and forms bound systems with other bodies.

It was a great satisfaction to find out in 2021, during one of my enquiries into the origins of the kinetic theory of gases, that similar ideas were considered in 1847 by John Herapath, whose work on the kinetic theory of gases was motivated by his willing to understand the thermal expansion of the aether in connection with gravity [2].

In “Fundamentals of a Theory of Aether – Part 1” [3] the magnetic effect of an electric current in a wire was explained on a mechanical basis. The electrigen diffusion wave which represents the electric current acts on the aether surrounding the conducting wire and produces circular motions in the aether which we detect as a magnetic field. In this case the force between two parallel current-carrying wires can be shown to be attractive and repulsive, depending on the direction of the electric currents in the two wires. Below is figure 8 from that work [3].



In the same article it was argued that working towards a completely mechanical description of the phenomena of electricity and magnetism requires the abandonment of the notion of “electric charge” as it does not offer an explanation of the *mechanism by which electric charges act on one another at a distance across space*.

Since the basic tenet of a mechanical theory is that the actions produced by matter are due to what matter *does*, not to what matter *is*, electrostatic interactions cannot be due to entities called “electric charges”, “positive” and “negative”, acting mysteriously on each other across empty space. Therefore, instead of introducing artificial concepts such as “positive” and “negative” matter, electrostatic attractions and repulsions have to be considered the result of vibrating particles and of the aether movement caused by these vibrations. The particles interacting electrostatically will then be more properly called *energy charged* instead of “electrically charged”.

I would like to stress here this idea of utmost importance: the concept of “electric charge” is a concept *invented* by scientists in an effort to explain the experimental observations of attractions and repulsions between objects. *Nobody has ever seen an “electric charge”*. What is seen are only attractions and repulsions between objects. “Electric charges” are *assumed to exist* just because attractions and repulsions are observed. Since particles vibrating in the aether produce such attractions and repulsions, their vibratory motion is sufficient to account for these interactions, and this makes the concepts of “positive” and “negative” “charges of electricity” an unnecessary invention.

I have argued in two previous works [1] [4] that Newton's 2<sup>nd</sup> law of motion ( $F = m a$ ) can be explained hydrodynamically as a force of resistance exerted by the aether on the object accelerating through it. This force of resistance is not a friction force since the aether has no viscosity – it is a force of resistance produced through a purely hydrodynamical effect due to the fact that the object *accelerates* through the fluid. Newton himself perceived this force as a force of resistance encountered when one tried to accelerate an object through space but could not say what was the origin of this force of resistance – only that it was proportional to the quantity of matter of the object (a quantity later called *mass*) – and to the acceleration of the object. The figure below is from [4].

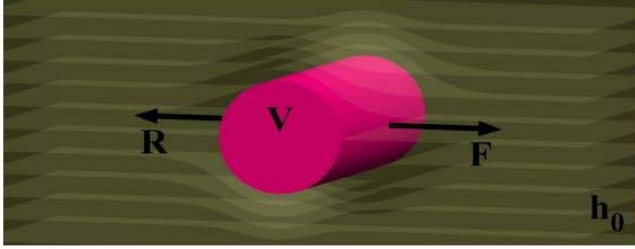

Aether hydrodynamic  
resistance

$$R = h_0 \cdot V \cdot \frac{\partial u}{\partial t}$$

A cylinder of volume  $V$  accelerated through an ideal liquid like the aether encounters from the liquid a resistance proportional to its volume  $V$  and the acceleration.

Newton's  
2<sup>nd</sup> law

$$F_i = m \cdot \frac{dv}{dt}$$

**Inertia is a hydrodynamical effect in the aether**

All of the above, discussed in more detail in [1], [3] and [4], point towards several important conclusions. Thus, explaining gravity as a buoyancy force in the aether [1], explaining the magnetic effect of the electric current as a mechanical action in the aether [3], explaining Newton's 2<sup>nd</sup> law of motion as a hydrodynamical force in the aether [4], and explaining the interference of light by admitting that light is a wave in the aether which in the case of light acts as a medium that transmits the oscillations from the light emitting source (Thomas Young), should be enough evidence for the *existence* of the aether, and also for its properties: the aether is a *compressible, inviscid* liquid that *obeys the equations of fluid dynamics* of continuity, conservation of momentum and energy.

In electrostatic phenomena observations show that no light is produced when particles attract or repel one another at a distance and this shows that in these phenomena the aether behaves in a simpler way. Thus, the non-radiative character of electrostatics means that the vibrating particles produce no waves in the aether, only its periodic flow. The periodic aether flow caused by the vibrating particles can be then considered *incompressible*, which makes CFD computations a lot less demanding than a compressible flow regime.

When two vibrating particles are considered, one produces periodic aether flows which interact with the surface of the other vibrating particle and gives rise to static pressures upon the latter's surface. The action of the second particle upon the first is similar. Solving the equations of fluid dynamics for the case of pairs of particles vibrating at a distance from one another in the liquid aether will give the pressures acting on each of them due to the combined effect of their own vibration and that of the aether flow created at their location by the vibration of the other. The pressures can then be expressed as forces acting on each of the particles vibrating in the aether, which

are in fact forces on particles “electrically charged” interacting at a distance in space. In this work cases have been studied in which the two particles are of the same size, vibrating with identical frequencies in phase or with various phase differences, and separated at various distances from each other. As it will be seen in what follows, attractive and repulsive forces are born depending on these different conditions. As a general rule, it can be said that the attractions and repulsions between vibrating particles are caused by the change of the static aether pressure in the space between particles and, as such, the mechanism is not very different conceptually from an old idea proposed by Dortous de Mairan [5].

## Historical background

In the first years of the discovery of light spectra emitted by the atoms of substances, scientists were looking at ways to relate the different frequencies of the radiations to the normal vibration modes of the atoms regarded as *vibrating structures* [6] [7] [8]. It was believed that the vibrations of atoms were transmitted through the aether as waves and that atoms vibrating in different modes with different frequencies produced the observed spectra in a way very similar to what happens with vibrating objects (strings, drums, bells, tubes) that produce sounds propagated through air. This is considered the first period in the development of the field of spectroscopy, and it has been called the *acoustic period* [9]. The *bell-hypothesis*, for example, was advanced in this period [10] to account for the fact that elementary substances produced different spectra at different temperatures and for different types of excitations (flame, arc, spark). It was believed that just as bells struck differently produce sounds of various sets of frequencies in air, so the atoms of substances would produce different spectra through the aether according to the mode of excitation.

The acoustic period was characterized by intensive measurements of the frequencies of radiation composing the spectra of elements with the aim of finding *harmonic relationships* between these frequencies. It is believed [11] that Balmer's discovery of a simple but *non-harmonic* formula relating the frequencies of radiation emitted by hydrogen atoms put an end to the *acoustic period* as many researchers shifted their attention to finding formulas similar to Balmer's in the spectra of other elements.

It must be argued that expecting the atoms of a substance to emit radiations with frequencies obeying *harmonic relationships* was unrealistic because only in simple systems such as strings and air tubes are encountered normal modes of vibration multiples of a fundamental frequency, and thus only such simple systems give rise to *harmonic relationships* between their vibration modes. In contrast, two dimensional vibrating objects such as plates do not have *harmonic relationships* between their frequencies. It should then not come as a surprise that atoms, as three dimensional vibrating structures, do not have vibrating modes in simple harmonic relationships. It can be seen then that *the acoustic model of the atom* has been dropped on no serious grounds, and treating atoms as vibrating structures when emitting light is still permissible and desirable especially for those who aim to find a mechanical explanation for the phenomena known as electrical, magnetic and optical. A vibrating atom is a good starting point when attempting to account for the atomic spectra and it is also a good starting point when attempting to account for the cohesion forces between atoms that lead to the formation of molecules, liquids and solids - and this is because *objects vibrating in a fluid act on one another with forces of attraction and repulsion* [12].

What happened after the acoustic period is well-known: a historical period more than a century long of confusion and illogical science in which the atoms of elements have been modeled using electrostatics and “electric charges”. This period continues to this day and is characterized by completely ignoring the explanation of the emission of light waves through the vibration of atoms, and by adopting instead nonsensical models and mechanisms stemming from Bohr's 1913 *postulates* for his planetary model of the atom [13]. Since it relies on postulates, this model lacks the main function for which it was proposed: *explaining* how atoms emit radiations and the structure of their spectra. Bohr's theory used the electrostatic attraction between the “negative” electron orbiting in “allowed” paths around a “positive” nucleus, without actually explaining what is the mechanism of the electrostatic attraction between the electron and the nucleus. In Bohr's atom light is mysteriously emitted when an electron “jumps” from one “allowed orbit” to another and not when it is actually expected to do so, namely during its accelerated motion within one orbit. Bohr's theory was even incomplete, in that it accounted for Balmer's formula only, which was applicable to the simple spectrum emitted by hydrogen, while for the other elements it needed correcting terms [14], for which supplementary assumptions regarding the atom had to be made. Sommerfeld's atom was derived from Bohr's but contributed nothing towards explaining the radiation mechanism of an atom

or its stability. The atomic model based on Schrodinger's equation attempted to bring the wave equation into the description of the atom and is closer to the truth in that *the time independent Schrodinger equation is almost identical with the wave equation that describes mechanical waves on three dimensional surfaces* which is the state of a vibrating atom when emitting light. Schrodinger's approach to atomic theory has, however, similar deficiencies: lack of an adequate mechanism that explains how atoms emit radiation [15].

The difficulties caused by the atomic theory based on electrostatics and "electric charges" has surfaced in chemistry as well, for example in the fact that the nature of chemical bond is still not completely understood. Lewis' brilliant theory that atoms bond only through a pairing of electrons [16], inspired Pauling to initiate the unification of all chemical bonds (ionic, covalent and metallic) into only one [17]: the covalent bond. Lewis and Pauling developments could lead to a theory in which *"electric charges" play in fact no role in bonding* because on the one hand chemical data points to the validity of such pairing while on the other hand the pairing of electrons to form a bond is obviously nonsensical since electrons are supposed to repel one another electrostatically, not to cause attraction and bonding. This inconsistency was noticed by Lewis as well [16] and was left for future generations of scientists to solve but no satisfactory solution has been put forward so far. Instead of following through with the unification of chemical bonds into one mechanism which will involve no "electric charges" but attraction and repulsion caused by the vibration of atoms and molecules, we are still learning that there can be three different types of chemical bonds *for the same atom*: ionic, covalent and metallic. It amazes me to see how far scientists are willing to go in pushing for electrostatics based theories that claim to explain chemical bonding and the cohesion of substances [18] without observing the obvious fact that as long as electrostatics itself remains unexplained these theories are not here to stay.

It seems therefore that the main difficulty of the atomic model of today is the very fact that it employs electrostatic attraction and repulsion, which are still unexplained phenomena. This status of electrostatics has been recognized many times in the past and is mostly overlooked today. Below is the way "Electricity" was defined more than 200 years ago [19]:

"[...] the *unknown* cause of such phenomena [i.e. the existence of an attractive power as the effect of friction on various bodies] [has been called] Electricity"

In conclusion, any theory (atomic model, chemical bonding, etc.) that uses electrostatics and action at a distance between "electric charges" must be considered incomplete.

## Bjerknes researches

The first earnest attempt towards a mechanical theory of electric and magnetic interactions was made by C. A. Bjerknes (helped by his son V. F. K.) [20]. His fluid mechanical experiments have been heavily influenced by Maxwell's early works in electrodynamics. Maxwell had used Bernoulli's equation of fluid mechanics and thus attempted to produce a theory of electricity and magnetism based on fluid mechanical equations applied to the aether. Bjerknes showed that it was possible to obtain attractions and repulsions through fluid mechanical interactions. I have discovered two critical erroneous interpretations of his experiments, which led to the eventual disregard of his work but, nonetheless, Bjerknes has the merit to have proved experimentally the viability of the idea of attractions and repulsions produced between objects in motion in a liquid. Below is shown the setup Bjerknes presented at the Paris Exposition Internationale d'Electricite in 1881 as reported in Nature [21] and disseminated widely in other works [22] [23] [24]. The impact of his experiments was so striking that it is said observers exclaimed: "*Maxwell should have seen this !*".

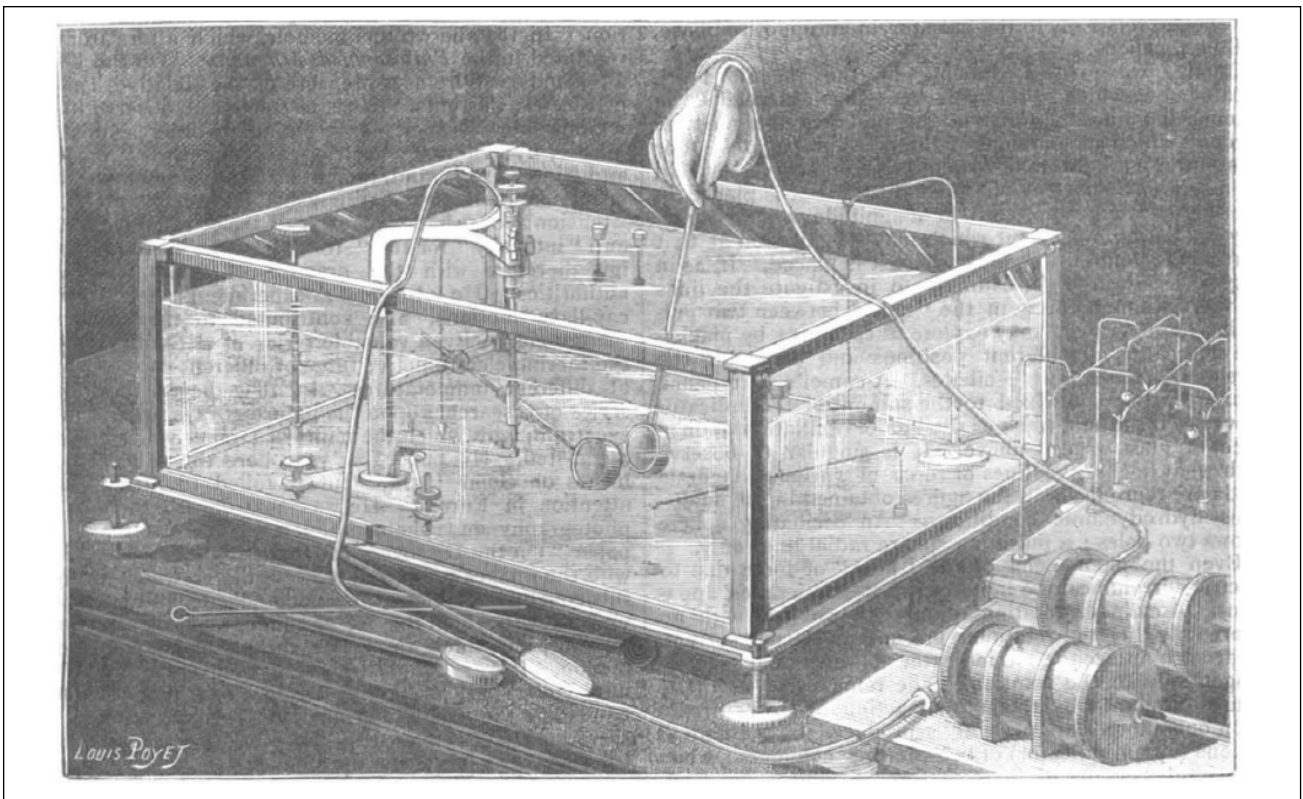

As it can be seen in the above figure, the experiment consisted of two drums immersed in water, which were made to pulsate - increase and decrease in volume - with the help of air pumps, and this action produced forces of attraction and repulsion between the drums. Initially Bjerknes wanted to use two small balloons instead of drums, but settled for drums as they were more stable when pulsating. The fluid flow between the two pulsating drums was also visualized through a very ingenious method shown on the figure on the right from [21]. Details of the experiments can be found in [20] and [23].

There are two critical interpretations of these experiments that I see as erroneous:

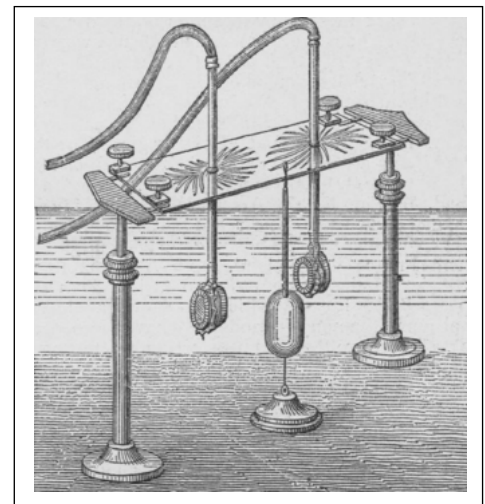



(i) The phases of pulsations have been misjudged.

Bjerknes experiments have used drums which expanded like balloons in both directions (see the figure at the right) and when both drums expanded and contracted in the *same time* they theoretically pulsated in the *same phase*, which was considered to correspond to two “like charges” (*same phase* corresponded to “same/like charge”). Figures 122, 123, 126 and 127 are from [23]. Figures 5a and 6a are from [20] and show what Bjerknes called “lines of oscillation”, visualized with the method showed above.

In terms of the forces acting between the drums as a result of their pulsations with the *same phase*, experiments showed that the two drums *attracted one another* and this situation led to the experiment showing that “like charges” attract one another, which is contrary to what is observed in electrostatics.

Consistent with these observations, when the drums expanded and contracted in *opposite phase* (one contracted while the other expanded, see the figure at the right) they *repelled one another*, which led to the conclusion that “opposite/unlike charges” repel one another, again contrary to what is observed in electrostatics experiments.

Since in electrostatics “like charges” repel and “unlike charges” attract one another, and Bjerkens hydrodynamic experiments seemed to show that two drums vibrating with same phases attract one another while when vibrating with opposite phases repel one another, a mismatch was perceived to exist between electrostatics and hydrodynamics and this was one of the reasons for the abandonment of any hope that electrostatics can be explained as an action between vibrating structures mediated by the liquid aether.

The error here is that the phases of drums pulsations (which is what Bjerknes called

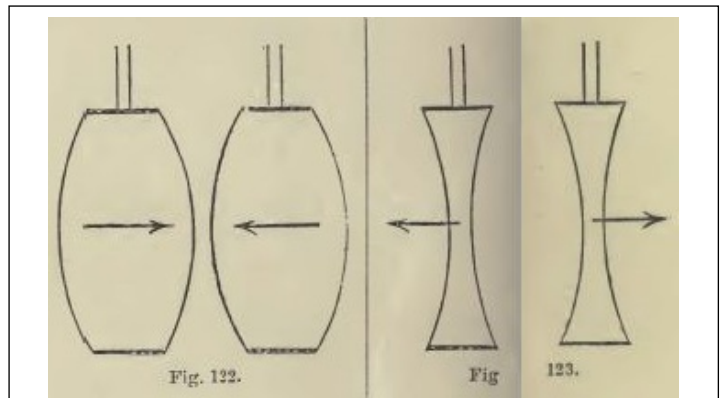

ATTRACTION. SAME PHASE = LIKE CHARGE

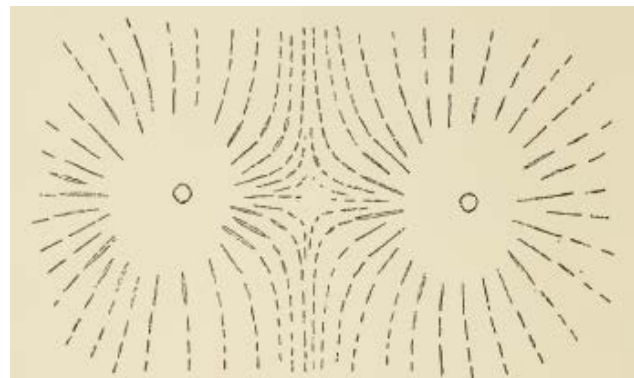
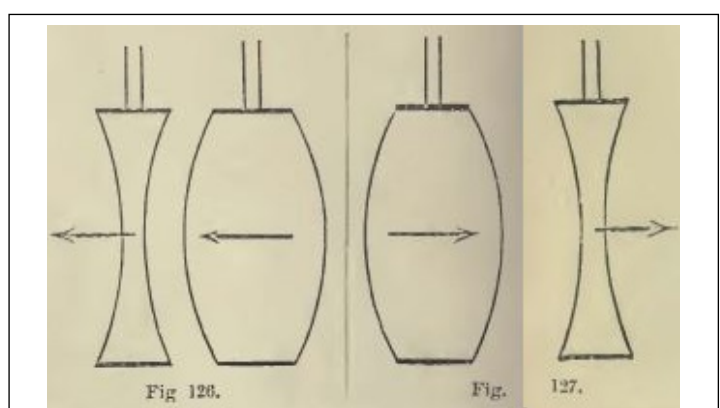

Fig 5a



REPULSION. OPPOSITE PHASE = UNLIKE CHARGE

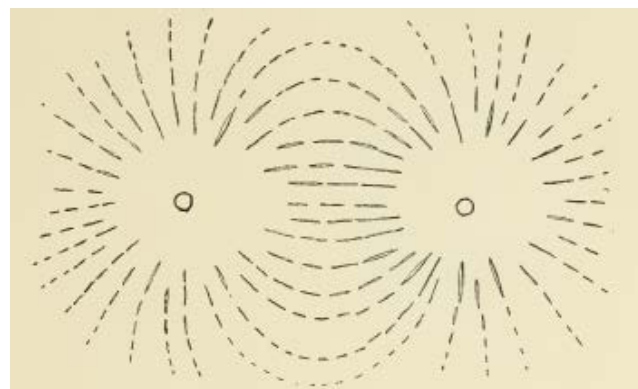
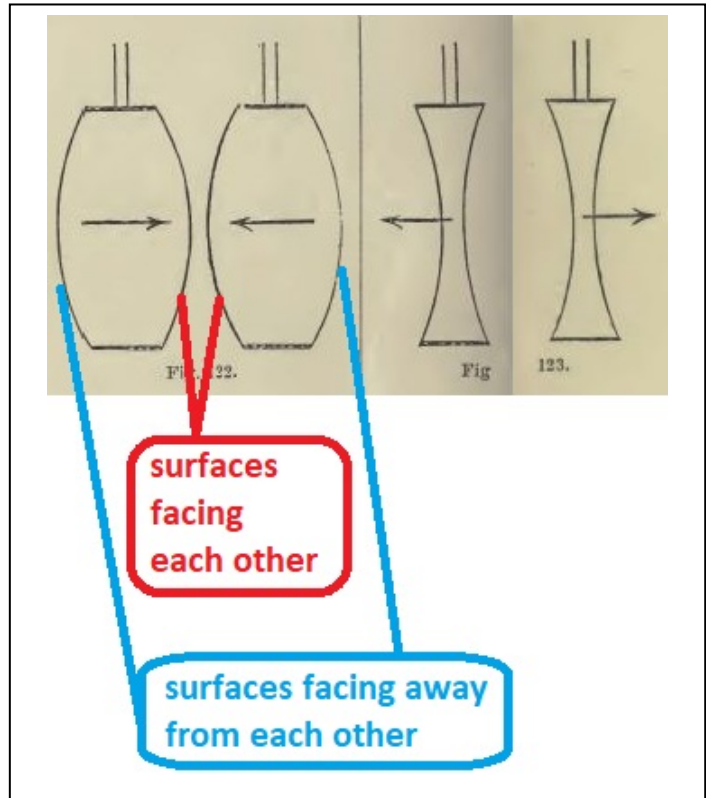

Fig 6a

the periodic expansion and contractions in the volume of the drums) have been misjudged because *in the interactions between the pulsating drums only the movements of those surfaces of the drums that face each other are important*, the movements of the surfaces of the drums facing away from each other are irrelevant (see the figure on the right).

I have verified that the above is true with CFD methods, first by successfully reproducing Bjerknes experiments with pulsating drums and then by considering, for each drum, only that surface that faces the other drum, each drum thus becoming only a membrane. I have obtained that two membranes vibrating in phase (corresponding to “like charges”) will repel one another, while two membranes vibrating in opposite phase (corresponding to “unlike charges”) attract one another. The electrostatic attractions and repulsions and their fluid mechanical counterpart are thus perfectly identical. These will be shown in the next section.



The electrostatic attractions and repulsions and their fluid mechanical counterpart are thus perfectly identical. These will be shown in the next section.

(ii) The “lines of oscillation” were considered to be analogous to the lines of force between two electric charges

This is an erroneous interpretation of Bjerknes experiments because in electrostatics the lines of force are mapped using a test charge, while in Bjerknes experiments the lines of oscillation were not mapped using a pulsating drum. In other words, there should have been, besides the two pulsating drums, a third pulsating drum of very small dimensions and the direction of the force acting on it be mapped.

The to-and-fro movement of aether along a line (straight or curved) may very well correspond to the electric field strength *in the absence of a test charge*, but not to the electrostatic force acting on a test charge used to map the field between two charges.

## CFD reproduction of Bjercknes researches. Extension of Bjercknes researches

The setup used in the reproduction of Bjercknes researches with computational fluid dynamics (CFD) is shown in the figures below.

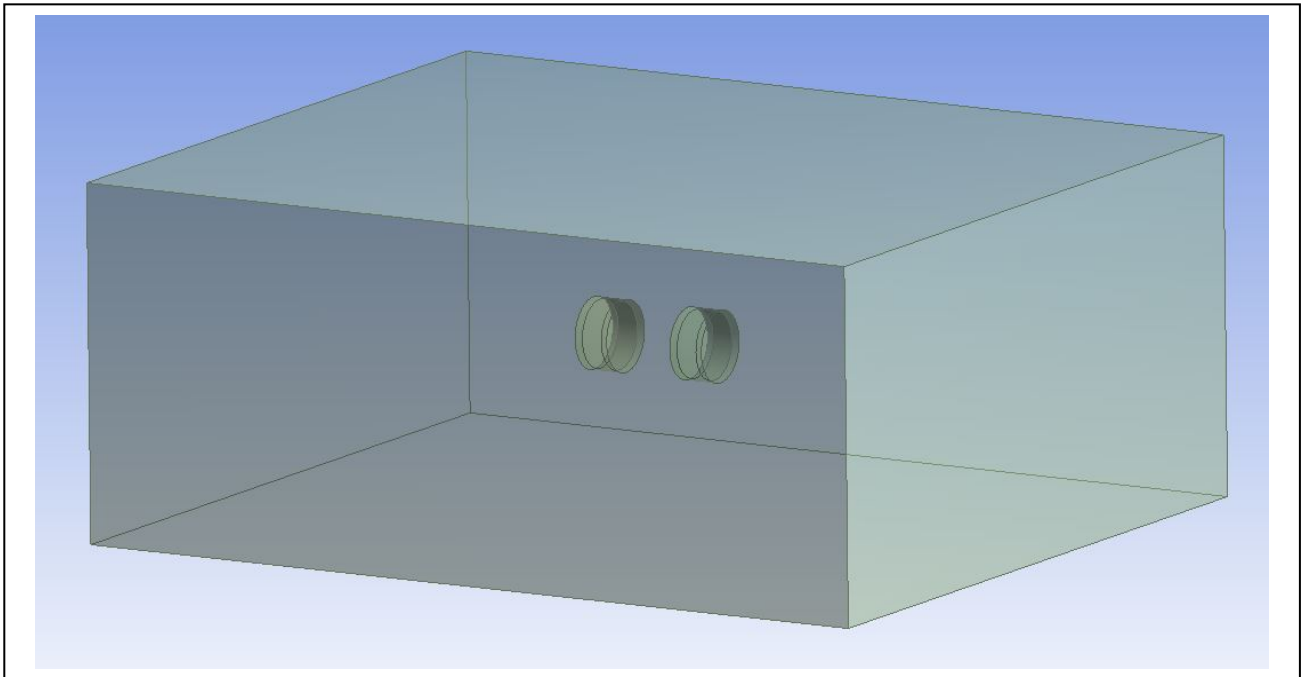

The physical quantities have been kept as close as possible to the original:

0.4m x 0.4m x 0.2m (tank size or fluid domain size),

0.04m (drum diameter),

0.02m (drum length),

8ms (drum vibration time period),

1000kg/m<sup>3</sup> density of inviscid, incompressible liquid.

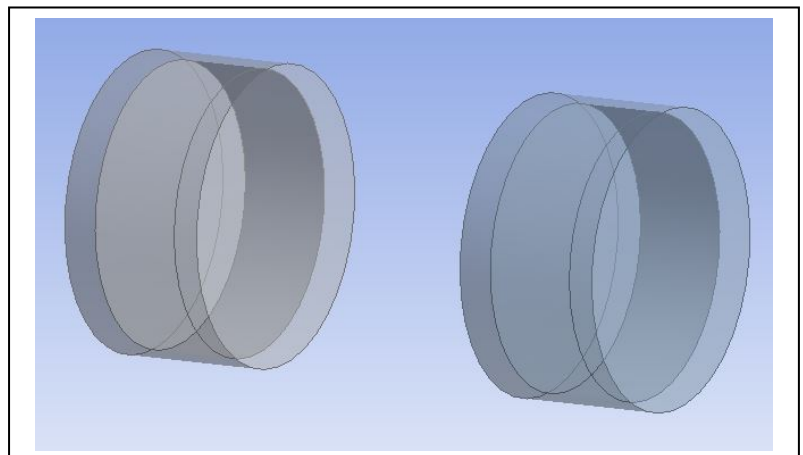

A close-up of the drums is shown in the two figures on the right.

Similar to the original Bjercknes experiments, the two surfaces of the drums were caused to vibrate outwards and inwards, pushing on the liquid in which they were immersed.

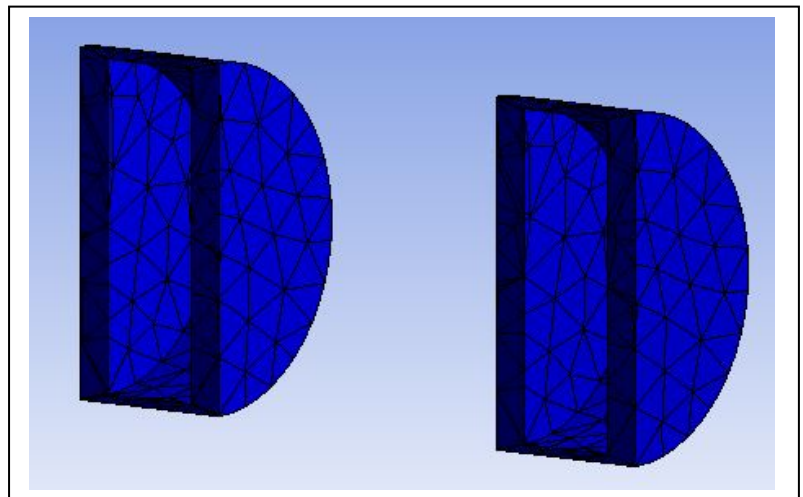

The forces acting on the two drums when separated by a distance of 0.04m, as well as a snapshot of the streamlines – which change in time – are shown below.

It is observed that there is attraction between the two drums when pulsating in phase (left picture)

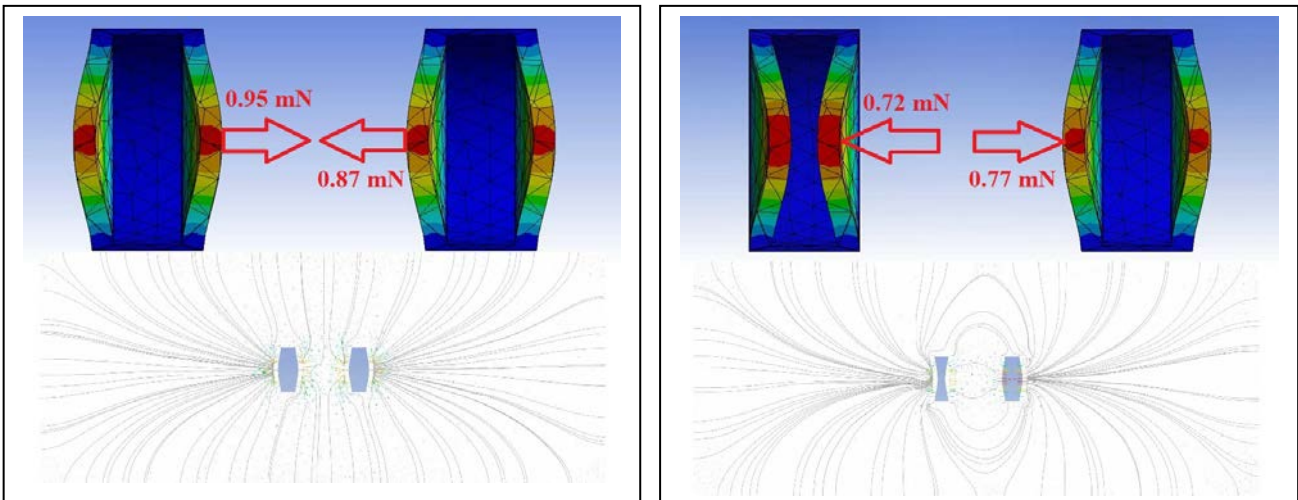

and repulsion when pulsating in opposite phase (right picture), just as is observed in Bjerknes experiments. It can be said that this validates, if not entirely at least partially, the CFD setup and the method used.

Next, Bjerknes' researches have been extended with the aim of correcting the error in the interpretation of the phase of pulsation in his original experiments, as discussed in the previous section. The drum surfaces facing away from each other were made to move in the same direction as the drum surfaces facing each other. The results were *not qualitatively different*, only the magnitudes of the forces decreased.

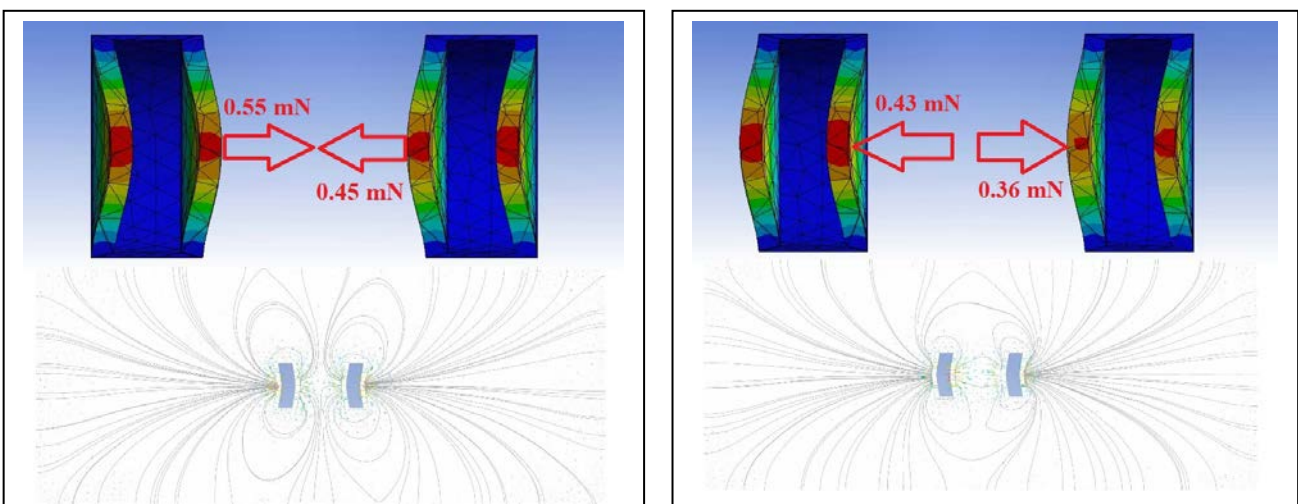

The fact that, *irrespective of how the surfaces facing away move*, there is attraction between drums pulsating in phase and repulsion between drums pulsating in opposite phase, shows that *these surfaces do not play a qualitative role in the interaction between the two drums*. This shows that *only the movement of the surfaces facing each other are important*. In the former case, when attraction is observed, these surfaces move towards and away from each other, i.e. in opposite directions, and so they should be considered as vibrating in opposite phase. In the latter case, when repulsion is observed, the surfaces move in the same directions, and so the surfaces should be considered as vibrating with the same phase.

It can be seen then that the designation of phases is exactly the opposite to that made by Bjerknæs. It was this misjudgment of the phases of vibration the reason for which his hydrodynamic experiments were considered contrary to the laws of electrostatics, and therefore incompatible with them. With the correct designation of phases however, we have:

**surfaces vibrating in the same phase repel one another and surfaces vibrating in opposite phase attract one another**

which is compatible with the law of electrostatics:

**like charges repel one another and unlike charges attract one another.**

In order to completely verify the above, CFD calculations were performed in which, instead of two drums having two vibrating surfaces each, only one vibrating surface, called membrane, has been considered. The results are shown in the following diagrams, where it can be seen that the above laws have been verified.

Only the surfaces of the drums facing each other have been considered, as the surfaces facing away from each other do not play a qualitative role in interactions.

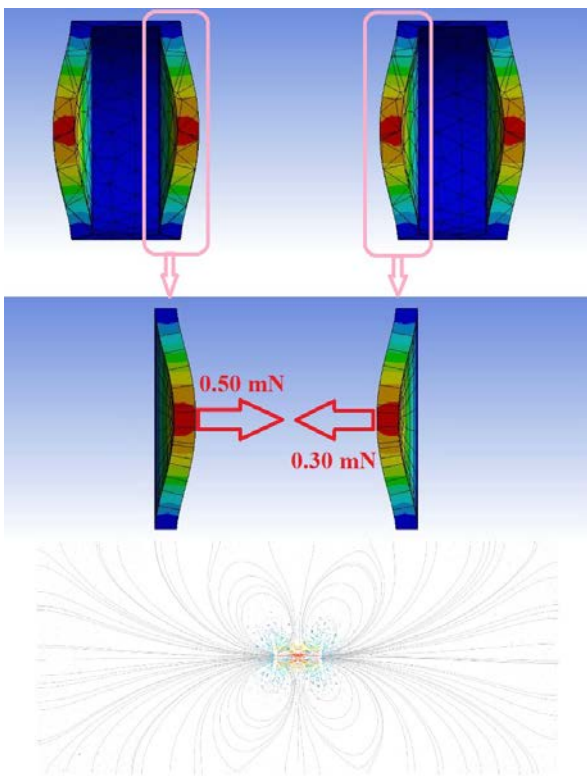

It is observed that these surfaces, called membranes, attract one another. The membranes vibrate towards and away from each other, i.e. in opposite directions, and therefore they should be considered as vibrating in opposite phase. Membranes vibrating in opposite phase attract one another, which is consistent with the law of electrostatics “unlike charges attract”.

Only the surfaces of the drums facing each other have been considered, as the surfaces facing away from each other do not play a qualitative role in interactions.

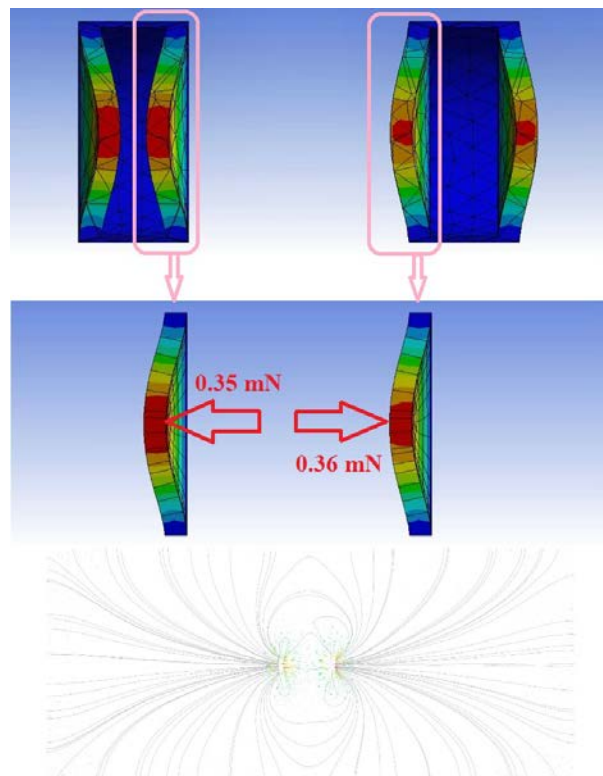

It is observed that these surfaces, called membranes, repel one another. Both membranes vibrate to the right and to the left in the same time, i.e. in the same directions, and therefore they should be considered as vibrating with the same phase. Membranes vibrating in the same phase repel one another, which is consistent with the law of electrostatics “like charges repel”.

Finally, this investigation would have been incomplete without checking whether the law is true for different separation distances between the membranes. The graph below shows that this is indeed the case, and that membranes vibrating in opposite phase attract one another over a wide range of distances and that membranes vibrating in the same phase repel one another over the same range.

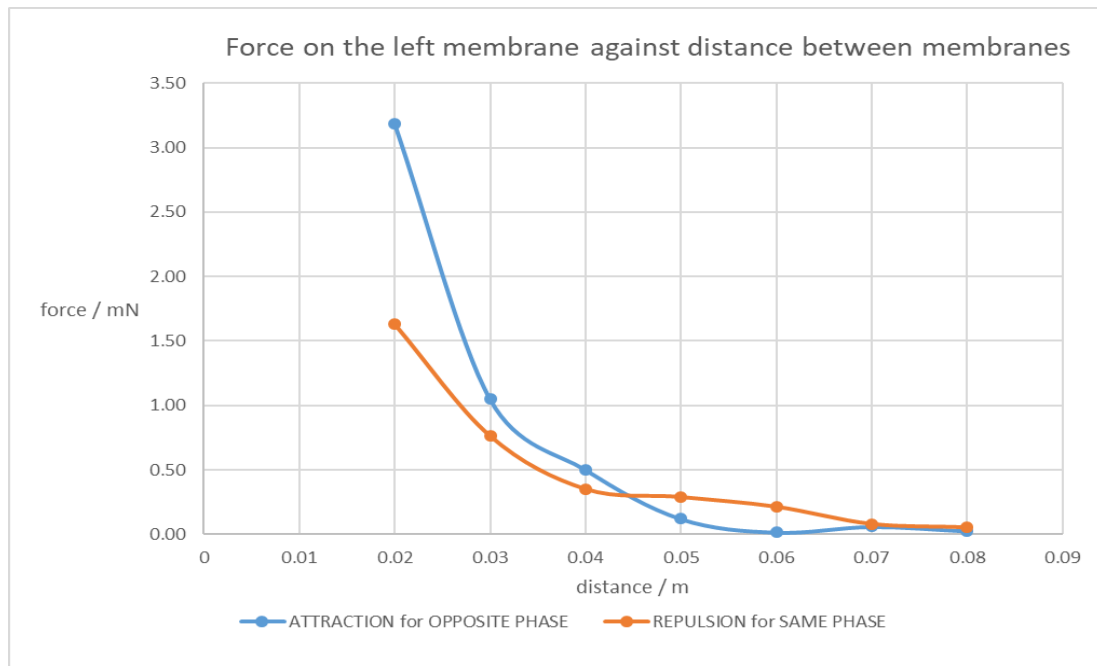

### Membranes vibrating with various phase differences

Vibrating membranes are probably the simplest structures which can be considered for the study of electrostatic attractions and repulsions. In the previous section it was discussed how CFD methods showed that membranes vibrating in opposite phase (180 deg phase difference) attract one another and that membranes vibrating with the same phase (0 deg phase difference) repel one another.

It is also very important to know how two vibrating membranes interact with one another when their phase differences are not exactly 0 or 180 degrees. One would expect a smooth transition between attraction and repulsion when one passes through all the possible values for the phase difference, i.e. from 0 degrees to 360 degrees.

The table below shows how the force (in mN) on the left membrane changes with the phase difference and distance from the right membrane.

distance / m	phase difference / degrees							
	0	45	90	135	180	225	270	315
0.02	-1.63	-1.07	0.88	2.66	3.19	2.52	0.69	-1.01
0.03	-0.76	-0.57	0.16	0.85	1.05	0.73	0.00	-0.59
0.04	-0.35	-0.28	0.06	0.39	0.50	0.40	0.06	-0.24
0.05	-0.29	-0.25	-0.08	0.07	0.12	0.07	-0.10	-0.24
0.06	-0.21	-0.21	-0.11	-0.02	0.02	0.00	-0.09	-0.17
0.07	-0.08	-0.07	-0.01	0.04	0.06	0.05	0.05	-0.06
0.08	-0.05	-0.05	-0.02	0.01	0.03	0.03	0.00	-0.03

It can be seen that, in general, the forces of attraction (positive values) appear centered around 180 deg phase difference and grouped in the range 135 – 180 – 225 deg phase difference for all separation distances and the forces of repulsion (negative values) appear centered around 0 deg phase difference and grouped in the range 315 – 0 – 45 deg phase difference for most of the separation distances. There is also an ambiguity in the kind of forces for 90 and 270 deg phase differences: for some distances they are attractive, for some they are repulsive and forces very close to zero have also been found. This aspect will be investigated further.

## Conclusion

The present work demonstrated the promising possibilities opened up by the treatment of electrostatic attractions and repulsions in vacuum as interactions between structures vibrating in the liquid aether.

The perfect consistency between the laws of attraction and repulsion found in electrostatics with those found in fluid dynamics show that the concept of “electric charge” can be successfully replaced with that of *energy charge*, the energy being that of the vibrating object.

The far reaching consequences of this approach have been mentioned in this work and affect every aspect of the physical and chemical science that uses “electric charges” and the unexplained attractions and repulsions between such “positive” and “negative” “electric charges” acting at a distance across space: atomic theory, chemical bonding, emission of radiation, electrochemistry, thermoelectric phenomena, conduction of electricity, etc.

So much work still needs to be done. Many more studies are needed in order to develop a comprehensive picture of how structures vibrating in a liquid interact with one another: different sizes and shapes of vibrating objects, objects vibrating with different frequencies, etc. An outstanding issue is to see how CFD can replicate the interaction between two parallel current-carrying wires, an idea discussed in [3] and which in fact inspired me to finally transition towards using CFD tools to explain the electrostatic, magnetic and electromagnetic forces.

## References

- [1] Ionel DINU, The Origin of Gravitation (2007)  
<https://www.researchgate.net/publication/254957884> The Origin of Gravitation
- [2] J. HERAPATH, Mathematical Physics, WHITTAKER AND CO. (1847), p xi-xl (Vol 1), p 231-348 (Vol 2)
- [3] Ionel DINU, Lori GARDI, Fundaments of a Theory of Aether - Part 1  
<https://www.researchgate.net/publication/343291302> Fundaments of a Theory of Aether - Part 1  
YouTube Video: <https://www.youtube.com/watch?v=CBY7hteMATg&t=1s>
- [4] Ionel DINU, Rudiments of a Theory of Aether (2010) p 22-23, The General Science Journal  
<https://www.gsjournal.net/Science-Journals/Research%20Papers-Astrophysics/Download/2370>
- [5] J. S. ROWLINSON, A Scientific History of Intermolecular Forces, Cambridge University Press (2004), p 41
- [6] W. M. HICKS, A Treatise on the Analysis of Spectra, Cambridge University Press (1922), p 18
- [7] A. FOWLER, Report on Series in Line Spectra, The Physical Society of London (1922), p 7-8
- [8] H. SCHELLEN, Spectrum Analysis, D. APPLETON AND CO. (1872), p 429 (Appendix A  
Johnstone Stoney On the cause of Interrupted Spectra of Gases)
- [9] A. C. CANDLER, Atomic Spectra Vol 1, Cambridge University Press (1937), p1-2
- [10] N. LOCKYER, Inorganic Evolution as Studied by Spectrum Analysis, MACMILLAN AND CO. (1900), p 19-20
- [11] G. P. HARNWELL, J. J. LIVINGOOD, Experimental Atomic Physics, MCGRAW-HILL (1933), p 227
- [12] (A) V. F. K. BJERKNES, Fields of Force, The Columbia University Press (1906), p 32  
(B) On Approach caused by Vibration. By various Authors, Edited by Frederick Guthrie, THE LONDON, EDINBURGH, and DUBLIN PHILOSOPHICAL MAGAZINE AND JOURNAL OF SCIENCE, 4th Series, June 1871, p 405  
(C) H. A. LORENTZ, LECTURES ON THEORETICAL PHYSICS DELIVERED AT THE UNIVERSITY OF LEIDEN, VOLUME I AETHER THEORIES AND AETHER MODELS. KINETICAL PROBLEMS, MACMILLAN AND CO. (1927), Ch IV ATTRACTION AND REPULSION OF PULSATING SPHERES, p 58  
(D) C. C. KIPLINGER, ACOUSTIC ATTRACTION AND REPULSION, SCHOOL SCIENCE AND MATHEMATICS 18 (1918), p 346
- [13] N. BOHR, *Phil. Mag.*, 18, 1, 476, 857 (1913)
- [14] A. FOWLER, Report on Series in Line Spectra, The Physical Society of London (1922), p 10
- [15] G. N. LEWIS, Valence and the Structure of Atoms and Molecules, The CHEMICAL CATALOG COMPANY (1923), p 48
- [16] G. N. LEWIS, Valence and the Structure of Atoms and Molecules, The CHEMICAL CATALOG COMPANY (1923), p 58
- [17] L. PAULING, The Nature of the Chemical Bond, 2<sup>nd</sup> Ed, Oxford University Press (1939/1952), p 408
- [18] J. S. ROWLINSON, A Scientific History of Intermolecular Forces, Cambridge University Press (2004), p 203 (Debye)
- [19] G. J. SINGER, Elements of Electricity and Electro-chemistry, Longman (1814), p 1
- [20] **V. F. K. BJERKNES, Fields of Force, The Columbia University Press (1906)**
- [21] (A) HYDRODYNAMIC ANALOGIES TO ELECTRICITY AND MAGNETISM, Nature August 18, 1881, Vol 24 Iss 616, p 360  
(B) BJERKNES' HYDRODYNAMIC EXPERIMENTS, Nature January 19, 1882, Vol 25 Iss 638, p 271
- [22] HYDRODYNAMICS AND ELECTRICITY, THE POPULAR SCIENCE MONTHLY, VOL



XXI MAY TO OCTOBER, 1882, p 253

[23] J. E. H. GORDON, SCHOOL ELECTRICITY, London (1886), p 227

[24] EXPERIMENTS OF M. BJERKNES. "INVERSE" IMITATION OF ELECTRIC AND  
MAGNETIC BY HYDRO-DYNAMIC PHENOMENA, Science December 31, 1881, Vol os-2,  
Iss 80, p 622